



DIAMOND
AUDIO TECHNOLOGY

**Passion Drives
the Soul**

Head Office
410 S. Benson Ln.
Chandler, AZ 85224

Tel: 480-813-6200
Fax: 480-813-6210

Service/ Tech Support
Toll Free 1-866-328-2834
tech@diamondaudio.com

www.diamondaudio.com

LIMITED WARRANTY STATEMENT

Diamond Audio Technology, Inc. (DAT) warrants all DAT products to be free of defects in material and workmanship for a period of one (1) year from the date of original purchase provided they are purchased from an authorized DAT retailer in the United States. However, the effective warranty period will be three (3) years if the products were purchased from and installed by an authorized DAT retailer.

What is covered: Parts and labor to effect repair or, at the sole discretion of DAT, replacement of either any malfunctioning or defective part(s) or the entire system should the system or any component part(s) thereof fail to perform as designed. Includes return freight via ground transportation to destinations within the United States.

What is NOT covered: Installation or setup and repair or replacement of the system or any parts thereof which, in DAT's judgment, fail or become damaged as a result of negligence, improper use, abuse, unauthorized modification or service, improper or inadequate packaging during shipment, installation by a non-authorized dealer, accident, or use for any purpose other than those for which this product was originally intended, or where the model's serial number has been removed, altered or defaced.

Who is covered: Original purchaser so long as they reside in the United States and can provide proof of the original date of purchase (e.g., store receipt) from an authorized DAT retailer.

OUTSIDE THE UNITED STATES: Customers outside the United States should contact their local sales office to obtain information on prices, exchange unit availability, instructions, service and warranty/non-warranty repairs.

Repair or replacement under this warranty is the exclusive remedy of the consumer. DAT shall not be liable for any incidental or consequential damages for breach of any expressed or implied warranty on this product. Except to the extent prohibited by applicable law, any implied warranty of merchantability or fitness for a particular purpose on this product is limited in duration to the duration of this warranty. Some states do not allow the exclusion or limitation of incidental or consequential damages, or allow limitations on how long an implied warranty lasts, so the above limitations or exclusions may not apply to you. This warranty gives you specific legal rights and you may also have other rights that may vary from state to state.

HOW TO OBTAIN WARRANTY SERVICE

In the event a DAT product should require servicing, you should (a) visit an authorized DAT retailer or (b) call the DAT Service Dept. at (866) 328 2834. To be eligible for warranty service within a three (3) year period, the accompanying receipt of original purchase from an authorized DAT retailer must specifically note that dealer installation was provided.

Product returned for repair/service must be properly packaged and clearly marked with the Return Authorization (RA) number issued by DAT. If the RA number is not clearly marked on the package or no RA number was issued by DAT, the product may be refused upon delivery. DAT does not assume responsibility for lost or misdirected product.

Rev 0 32002 © 2002 Diamond Audio Technology, Inc.

All rights Reserved. Features and specifications subject to change without prior notice.



DIAMOND
AUDIO TECHNOLOGY

DS

Professional Reference Series Amplifier

300.4 & 600.4

Owner's Manual

Serial Number _____ Date of Purchase _____

www.diamondaudio.com

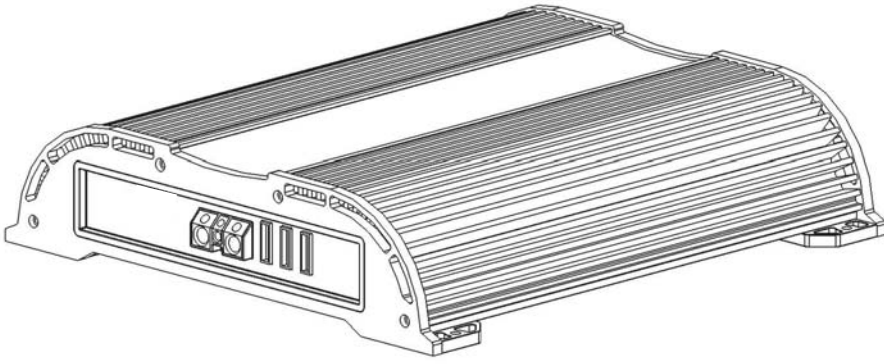

FEATURES

Technical

- Fully Regulated Power Supply
- Up To 5V RMS Input Signal Voltage Capability
- High pass x-over 12 dB/oct. 15 Hz-1.5 kHz
- High pass multiplier (x 10)
- Low pass x-over stereo 12 dB/oct. 50 Hz-5 kHz, mono (Ch 3/4) 24 dB/oct. 50 Hz-5 kHz
- RCA Outputs
- 2 oz. Silver Plated Copper Circuit Board
- Massive Proprietary Heatsink

Convenience/Appearance

- Fully Variable Electronic Crossovers
- Nickel Plated Solid Brass, Circuit Board Mounted, 4 Gauge Direct Power/Ground Connector Blocks
- Nickel Plated Solid Brass, Circuit Board Mounted, 10 Gauge Direct or Banana Plug Direct Speaker Connectors
- Fly Cut Billet Aluminum End Plates
- Fully Adjustable Mounting Feet

SPECIFICATIONS

Frequency Response:	10 – 50,000 Hz
Signal-to-Noise Ratio:	100dB
THD:	0.03%
Channel Separation:	80dB (min.)
Input Sensitivity:	.2 to 5V RMS
Input Impedance:	>20k Ohms
Power Supply Operating Range:	11 to 14.5V DC

DIMENSIONS

D5 300.4
Length: 12 1/2"
Width: 12"
Height: 2 3/4"

D5 600.4
Length: 17"
Width: 12"
Height: 2 3/4"

CONTINUOUS RMS OUTPUT POWER

Note: Full Rated Power is generated at all voltages between 11 and 14.5VDC.

D5 300.4
37.5W x 4 @ 4 Ohm Stereo
75W x 4 @ 2 Ohm Stereo
150W x 2 Bridged @ 4 Ohms
(minimum impedance)

D5 600.4
75W x 4 @ 4 Ohm Stereo
150W x 4 @ 2 Ohm Stereo
300W x 2 Bridged @ 4 Ohms
(minimum impedance)

CROSSOVER SPECIFICATIONS

Quantity: 2
Type: Fully Independent and Adjustable Highpass and Lowpass
Slope: 12 dB/oct. Stereo, 24 dB/oct. Lowpass Mono (ch 3/4)
Alignment: Butterworth

FUSE RECOMMENDATIONS

D5 Professional Reference Series Amplifiers come with circuit board mounted fusing. In addition to that we recommend that you install the correct size fuse/holder combination to the main power cable within 18 inches of the battery. This will protect your vehicle from fire damage due to a short circuit to the chassis or vehicle body. If a single amplifier is installed, follow the fuse recommendation below. If installing multiple amplifiers, add up the total fuse ratings of all installed amplifiers. This should be used as your main fuse rating.

Amplifier	Maximum Fuse Rating
D5 300.4	60
D5 600.4	90

A Word About Professional Installation...

We, the folks at Diamond Audio, highly advise the use of a factory authorized installation technician. System performance ultimately depends on proper installation. Your D5 Series amplifier is an awesome component that deserves to be professionally installed. If you still insist on installing the amplifier yourself, the following instructions should make it a little easier.

Before starting your installation, remove the negative battery cable before working on the positive terminal to prevent a short to ground. If a short does occur, current will continue to flow until the short is opened, the main fuse blows, or the wire melts (possibly taking out any nearby flammable object, wire loom, etc. causing a fire or other damage). Reconnect the negative terminal after all connections have been made.

MOUNTING YOUR AMPLIFIER

Warning — Amplifiers Generate Heat!

You can mount your amplifier in any position, even upside down. However, airflow must be maintained. Do not install your amplifier under carpets or behind airtight panels. Let the amplifier breathe. Without air circulation, your amplifier will shut down its power output to protect itself.

D5 Professional Reference Amplifiers do not utilize any fan driven cooling system. Care must be taken to provide a sufficient flow of air around the amplifier for the thermal management system to operate at peak efficiency. Air should be able to flow over the top and sides of the amp freely. Adding a fan to your system can be beneficial in keeping your amp cool. Be sure to allow at least 2 inches of space around the amplifier. Never mount your amplifier where it can get wet. Water damage is not covered by the warranty.

Mounting your amplifier inside an enclosure is not a good idea unless that enclosure is equipped with ventilation fans to circulate fresh air through the enclosure.

Your new *D5* amplifier features adjustable mounting flanges. Should they need to be moved to a different location, remove the self-tapping screws on the bottom of each mounting flange. Move the flange to the desired location. Carefully tighten the self-tapping bottom screws. Be careful not to over tighten these screws or damage to the head of the screws or stripping of the threads will result.

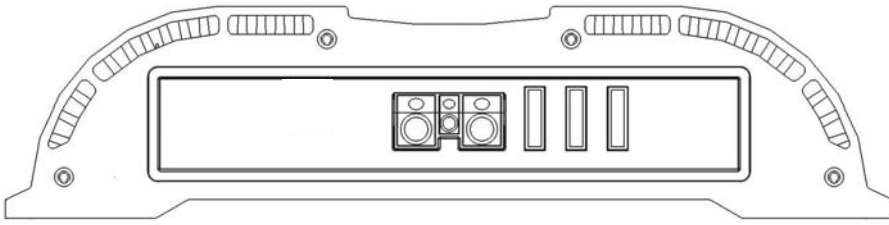

POWER/GROUND/REMOTE

D5 amplifiers need proper power and ground connections to deliver maximum performance and efficiency. This is typically the least understood part of the installation process. Voltage drops due to poor quality connections and/or poor grounding practices will rob your audio system of power that could be used for listening to music. These voltage drops will create increased current draw and will make it easier for noise to enter your system.

Your new amplifier has a fully regulated power supply. It is designed to make full power even if the voltage changes. It will draw more current at lower voltages to make that power. Try to ground your system to a single point in the vehicle.

The gauge of the power and ground cables must be capable of handling the current needed by the entire system. Power and ground cables must be of the same gauge. If the alternator is not capable of supplying enough power for both the vehicle AND the audio system, a high output alternator should be installed for best performance.

A Word About Batteries and High Output Alternators...

The battery in your car is a chemical storage device for electrical energy generated by the alternator. It is capable of briefly supplying high currents for cold starting the vehicle as well as powering other important electrical loads either partially or entirely for a limited period when the engine is off.

In order to supply the power required for ignition, lighting, large audio systems etc. a car needs its own efficient, reliable, and constantly available source of energy. When the engine is stopped, the battery is the vehicle's energy source. When the engine is running, the alternator is the on-board "electricity generating plant." It is the job of the alternator to supply power to all current-consuming loads (including the audio system).

Alternator output, battery capacity, and power demand of all electrical loads and systems must be matched as ideally as possible so the entire system is reliable and trouble-free in operation.

In the most basic of terms, this means that car audio is gasoline powered. Extra batteries are primarily for the extended operation of your audio system when the engine is off, or for SPL competitions where high sound pressure levels are generated for short periods of time. In which large battery racks are needed to provide the necessary current demanded by the many amps used.

D5 Professional Reference Series Amplifiers are capable of reproducing "concert level" volumes with incredible accuracy. Care must be taken to ensure that your vehicle is capable of supplying the voltage and current required by such a system.

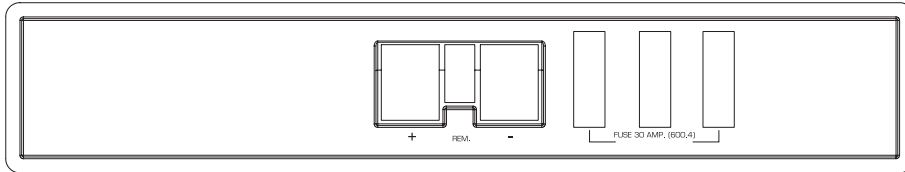

POWER (+12V)

Strip approximately 1/2 inch of insulation from the end of the power cable going to the amplifier. Insert the stripped cable into the power block on the end of the amplifier and tighten the Allen screw. Repeat for each amplifier installed.

GROUND

For low power systems, locate a fairly thick metal area near the amplifier(s). Inspect around and under the chosen area to make sure you won't drill into wires, brake or fuel lines, computers, etc. Remove any paint and carpet glue to a spot approximately 1 inch in diameter. Drill a hole into the middle of this area. Cut a length of ground cable long enough to go from the ground point to the amplifier. Terminate the ground cable with a ring connector and attach it to the bare metal using a bolt, star washer and nut. Seal the area from above and below to prevent rust. Strip approximately 1/2 inch of insulation from the other end of the cable and insert it into the ground block on the amplifier and tighten the Allen screw. For multiple amplifier systems, a ground distribution block is recommended. Cut a length of cable long enough to go from the ground distribution block to the amplifier. Strip approximately 1/2 inch of insulation from each end of the ground cable. Insert one end into the ground distribution block and tighten the Allen screw. Insert the other end of the cable into the ground block on the amplifier and tighten the screw. Repeat for each amplifier installed. Run a cable (the same gauge as the main power cable) from the ground distribution block to the negative terminal of the system battery.

Your *D5 Professional Reference Series Amplifier* is designed to accept up to 4 gauge power and ground cable.

A Word About

Amplifier Current Draw...

The following basic formula can be used as a quick guide to determine the total amperage draw of a mobile audio system. This formula is based on a 50% amplifier efficiency rating. *Diamond Audio D5* amplifiers are more efficient. Others may be less.

Formula:

Total amplifier rated RMS power divided by .5 = Total Input Wattage

$$\frac{\text{Total Input Wattage}}{\text{Battery Voltage}} = \text{Current Draw (in Amps)}$$

Example:

An *D5 600.4* amplifier has 4 channels at 75 Watts per channel RMS into 4 Ohms totaling 300 Watts. Work the formula as follows:

$$300 \text{ Watts} / .5 = 600 \text{ W}$$

$$\frac{600 \text{ W}}{12 \text{ V}} = 50 \text{ A Total Current Draw}$$

If the same amplifier is being driven to a 2 Ohm stereo or a 4 Ohm mono load, double the total wattage number:

$$(D5 600.4 = 600 \text{ W @ 4 Ohms Mono}) / .5 = 1200 \text{ W}$$

$$\frac{1200 \text{ W}}{12 \text{ V}} = 100 \text{ A Total Current Draw}$$

Note: If you are installing multiple amplifiers, add up the total current draw for all of them and choose the appropriate gauge based on the grand total.

TURN-ON CONNECTION (REMOTE)

Locate the terminal labeled "REMOTE" between the ground and +12V power connection points on the end of the amplifier. Your source unit should have a wire in its harness labeled "REMOTE" or "AMP TURN-ON." Some source units come equipped with a "Power Antenna" lead only. This should also work. Run this wire from your source unit to the amplifiers REMOTE connection. Strip approximately 1/2 inch of insulation from the wire. Insert the wire into the terminal, and tighten the Allen screw. Your *D5 Professional Reference Series Amplifier* will accept remote turn-on wire up to 10 gauge directly.

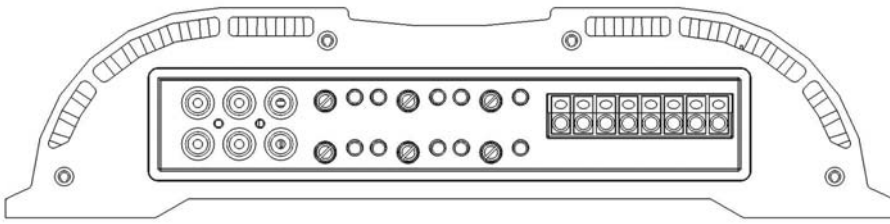

SPEAKER WIRING

Diamond Audio recommends using speaker wire of at least 16 gauge. Lay out the wire in the vehicle from the individual speaker locations to the amplifier(s). Observe safe wiring precautions.

Your *D5 Professional Reference Series Amplifier* will accept speaker wire up to 10 gauge directly. Locate the speaker terminal block on the end of the amplifier. Strip approximately 1/2 inch of insulation from the wire, insert the wire into the terminal, and tighten the Allen screw. Repeat for all speaker wires. Please observe our recommended minimum speaker impedances to prevent possible damage.

Banana Jacks using up to 8 gauge wire can be inserted into the speaker block. Remove the set screw completely and insert the Banana Jack into the end of the block.

BRIDGING

All pairs of Diamond Audio *D5* amplifier channels are capable of being bridged to a 4 Ohm mono output. Creation of the mono channel is accomplished by using the left channel positive (+) output connection of the amplifier for the speaker positive and the right channel negative (-) output connection of the amplifier for the speaker negative.

Note: *It is important that a 4 Ohm minimum total speaker impedance load is observed when bridging the amp! If an impedance load of less than 4 Ohms is used, you will eventually damage your amplifier and void your warranty.*

RCA INPUTS AND OUTPUTS

CH 1/2 & 3/4 INPUTS

The RCA cables from your source unit should be inserted here.

AUX. OUTPUT

These RCA outputs are used to provide filtered or unfiltered signals to an outboard processor or amplifier.

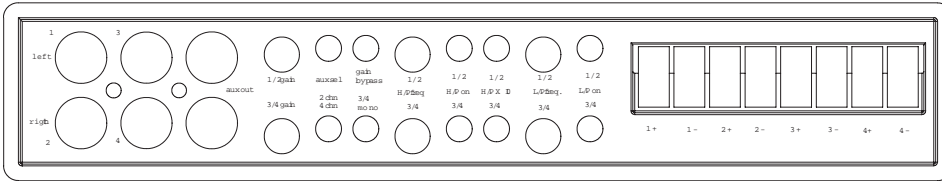

CROSSOVER

All Diamond Audio *D5* amplifiers employ one of the most flexible internal crossover sections currently available in mobile audio. They feature second-order 12dB/octave Butterworth filters. These filter networks sum to a flat response at their -3dB break points. This results in a smooth and seamless transition from one frequency band to the next. Butterworth filters provide maximally flat frequency responses when compared to other filter structures.

All crossover controls are mounted on the signal side of the amplifier. The *D5* 600.4 crossovers are continuously variable, lowpass from 50Hz to 5kHz, highpass from 15Hz to 1.5kHz or 1.5kHz to 15kHz using x10 button. Each pair of channels has an individual network that can be configured to Highpass, Lowpass, Bandpass or All-pass by simple switch selection. When switched off, they are completely out of the audio path. The Ch 3/4 crossover also features a mono/stereo switch that when pushed in to mono will series the two crossovers to a fourth-order 24dB/octave filter for subwoofer systems.

GAIN

This control matches the output voltage of the source unit or processor to the amplifier inputs. Rotating this control to the "MIN" mark (counterclockwise) configures your *D5* amplifier to accept input voltages as high as 5V RMS. This control should be set as low as possible. The basic procedure for setting input gains is as follows:

1. Adjust all amplifier gain controls to just above the minimum setting (fully counterclockwise).
2. Using the highest quality source (usually CD) play some music and slowly turn up the source unit until you can hear distortion. Now turn down the volume until the distortion stops. This is your maximum source unit level.
3. Turn up the amplifier gain until audible distortion starts. Turn down the gain to the point JUST BELOW the start of the distortion.
4. Repeat step 3 for all amplifiers in your system.

AUX. OUTPUT SELECT

Pushing this button "IN" selects the Aux. outputs to use the crossover settings on the amplifier. Leaving this button "OUT" bypasses the crossover and selects the Aux. outputs to run full range.

CH 3/4 INPUT SELECT

Pushing this button "IN" selects the 2 channel mode, meaning that channels 3/4 use the channel 1/2 inputs. Leaving this button "OUT" uses the channel 3/4 input in 4 channel mode.

GAIN BYPASS SELECT

Pushing this button "IN" bypasses the gain stage on the amplifier. This is used in systems with a pre-amp section before the amplifier or to slave the amp to a master amplifier. Leaving this button "OUT" is the default and uses the amplifiers gains as a normal input level match.

CH 3/4 MONO SELECT

Pushing this button "IN" combines the input signal to create a mono signal of channels 3/4 for use with subwoofer systems. Leaving the button "OUT" defaults the amp to normal stereo mode.

HIGHPASS FREQUENCY

Turning this control sets the Highpass crossover point from 15 Hz (fully counterclockwise) to 1.5 kHz (fully clockwise). This can be used as a subsonic filter if needed.

HIGHPASS ON/OFF

Pushing this button "IN" engages the Highpass filter. Pushing this button "OUT" will bypass the filter.

HIGHPASS X 10 SELECT

Pushing this button "IN" multiplies the highpass crossover frequencies times 10, 1.5 kHz to 15 kHz. Leaving the button "OUT" uses the highpass filter normally. (see highpass frequency section above for frequency points)

LOWPASS FREQUENCY

Turning this control sets the Lowpass crossover point from 50Hz (fully counterclockwise) to 5kHz (fully clockwise).

LOWPASS ON/OFF

Pushing this button "IN" engages the Lowpass filter. Pushing this button "OUT" will bypass the filter.

CROSSOVER FREQUENCY DIAGRAMS

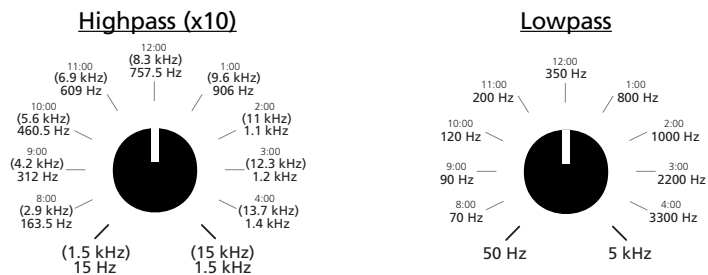

BASIC TROUBLESHOOTING

1. **Amplifier has no output.**

Is LED (located on power/ground endpanel) lit?

Yes: Make sure audio signal is present at RCA inputs. If no signal is present, use alternate signal source and try again. If signal is present, check configuration of crossovers. If still no signal, contact your authorized dealer.

No: Check power, ground and remote wire for +12V. Verify all connections. If voltages are correct and still no LED, contact your authorized dealer.

Note: The following steps apply to each pair of channels on your amplifier.

2. **Sound in one channel only.**

Reverse left and right RCA cables at amplifier inputs. Is the sound now in the opposite channel?

Yes: Reverse the input RCA cables in every product installed BEFORE your amplifier until the problem is found. Check RCA cables for open connections. Repair as necessary.

No: Check the speaker or speaker wires of the dead channel and repair as needed. If speaker and wire are OK, contact your authorized dealer.

3. **One or both pairs of amplifier channels "squeal" when operating.**

One or more speaker wires are shorted or one or more speaker voice coils are shorted or rubbing. If speakers and wires are OK, contact your authorized dealer.

4. **Amplifier volume cuts out or gets softer as music is playing without touching any system controls.**

Amplifier is going into thermal protection. Make sure amplifier has room to breathe. Preventing air from reaching the heatsink will cause the amplifier to overheat, as will running the amplifier at too low of an impedance. A fan can be added to aid in ventilation.

SYSTEM DIAGRAM 1



SYSTEM DIAGRAM 2

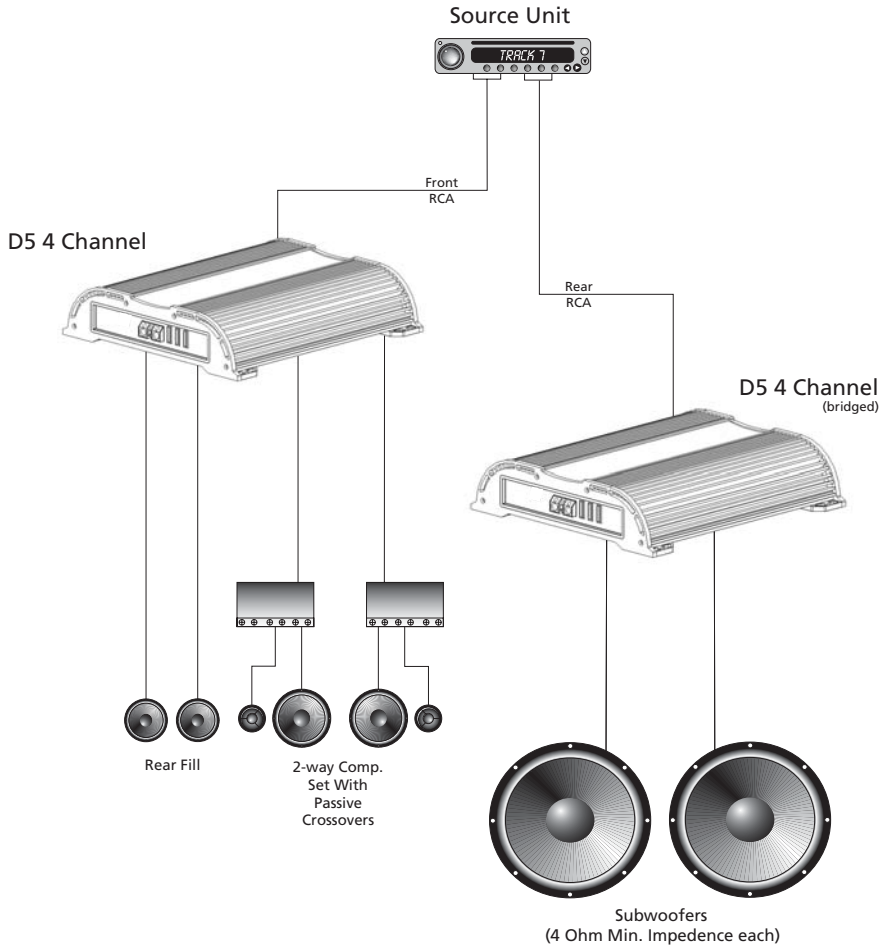

SYSTEM DIAGRAM 3

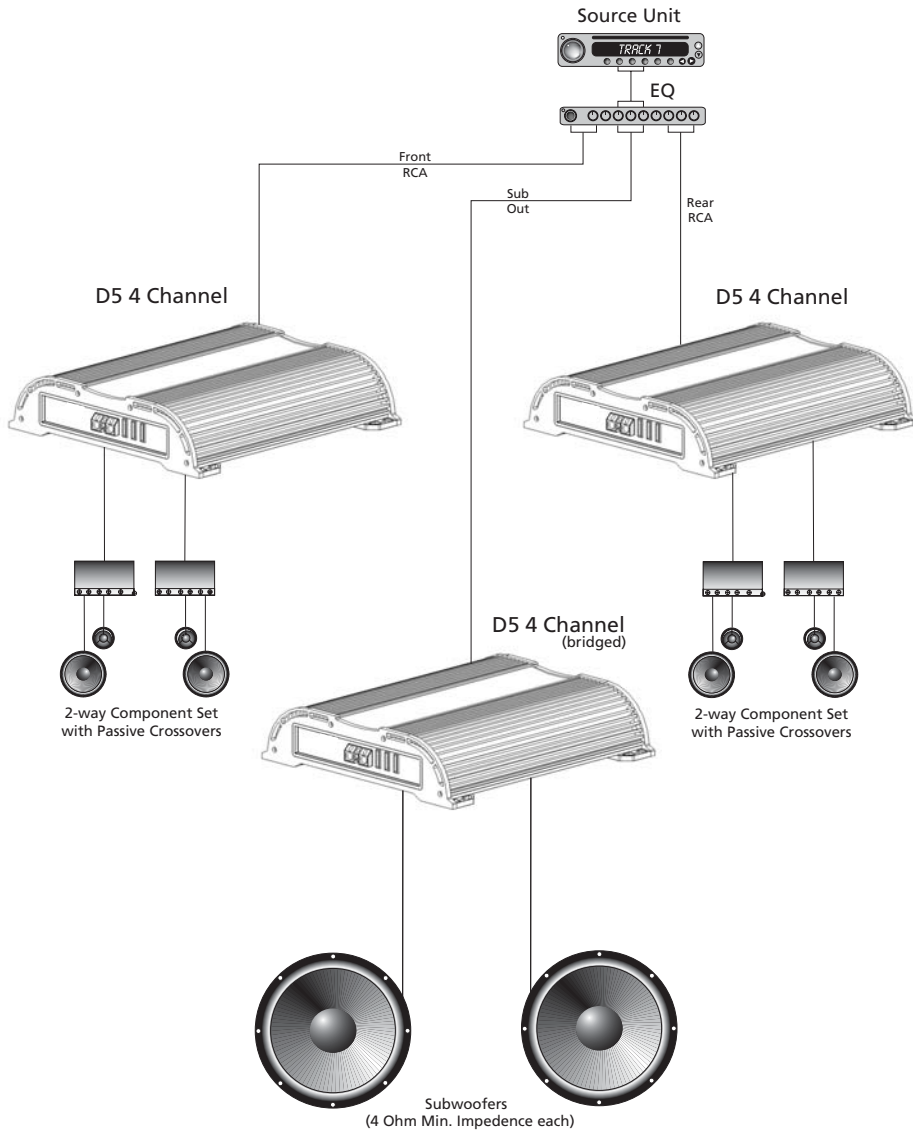

SYSTEM DIAGRAM 4

